

# HBD/8 SHLW BOLLARD

(Anti-terror / Heavy Duty - Fixed - Shallow Mount Model)

**CAME**  **ÖZAK**

**TECHNICAL SPECIFICATIONS**

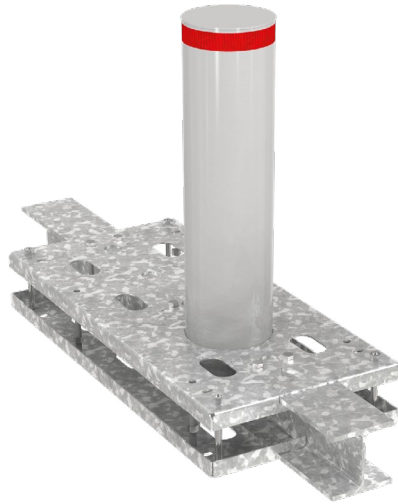

**PAS 68 (N3)**  
**IWA 14 (N3C)**  
**ASTM F2656 (C740)**

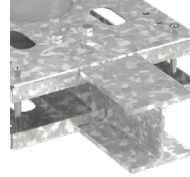

## Dimensions (mm)

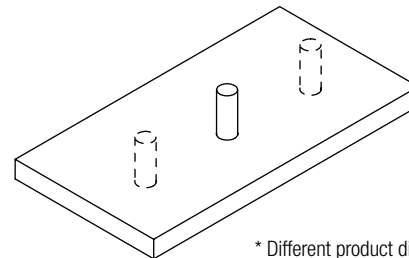
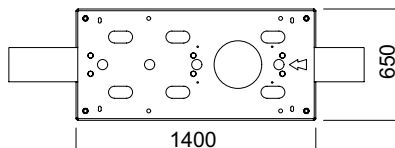
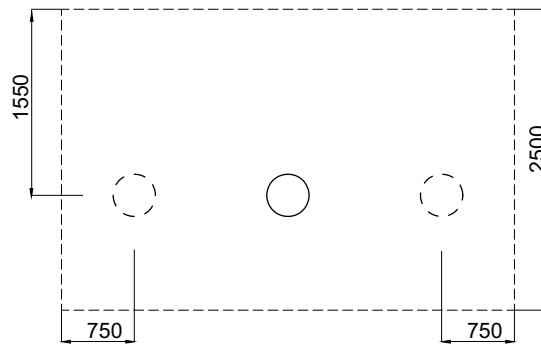
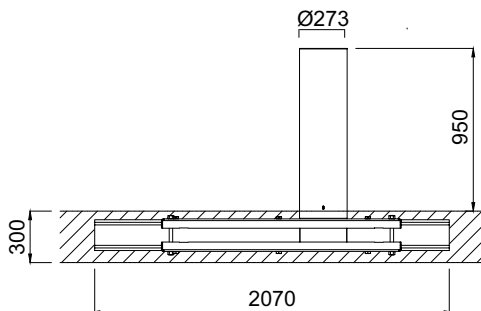

\* Different product dimensions are optionally available.

## Technical Features

### Crash / Impact Rating

Crash tested and certified according to:  
IWA 14-1:2013 Bollard V/7200[N3C]/64,  
PAS68:2013 Bollard V/7500[N3]/64, and  
ASTM F2656-18 C750/7200 standards (HBD 275 S 95/8 SRF model).

### Bollard Structure

950 mm high bollard pipe is made of Ø273 mm, 10 mm thick hot dip galvanised solid steel pipe with a reinforced design. Special star-formed, 10 mm solid steel bar and composite infilled inner structure for impact absorption distributed evenly to the whole body and increasing resistance. Impact surface is painted in RAL9006 (optionally in other RAL colors). Designed so that no vehicle crashing effect can displace it after embedded into the ground. Furnished with red (opt. white or yellow) reflecting strips. Bollard contains high resistant anchorage structure through 2 anchor plates with concrete immersion slits at the top and bottom, strengthened with "HEB" beams in the impact direction and adjustment bolts for levelling at 4 areas. Underground elements are fixed together by wedge type, 10.9 grade bolted and welded connection for utmost resistance reinforcement.

### Optional Features and Accessories

Removable structure (designed and produced to withstand impacts at ASTM F2656 M40, C740 (K-8), PAS 68 [N3]/64 and IWA 14-1 [N3C]/64 levels), demountable aluminium (electrostatic powder coated in body color or 304/316 grade stainless steel) bollard top lid with 360° visible red flashing LED indicators, stainless steel sleeve (304/316 grade), different colors, different product dimensions.

### Installation

Easy levelling with 4 bolts and installation to 300 mm shallow depth with steel rebar reinforcement and C30 grade concrete through ground mounting plate containing concrete immersion slits. Ground levelling and preparation works shall be carried on before pouring the concrete. Allowable bearing value of the ground shall be minimum 1/2 kg/cm<sup>2</sup>, if not, works shall be carried on to fulfil. Installation shall be done according to the manufacturer's instructions.