

RBD/4 SHLW BOLLARD

(Reinforced - Fixed - Shallow Mount Model)

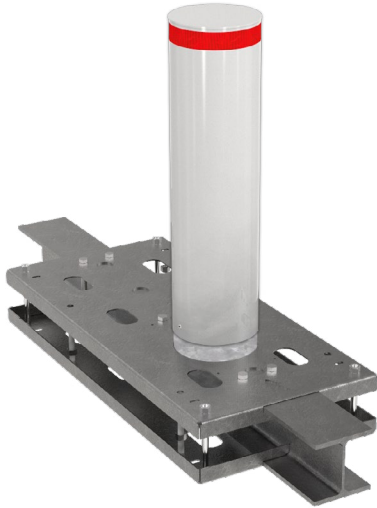

Dimensions (mm)

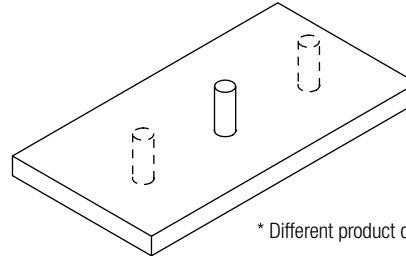
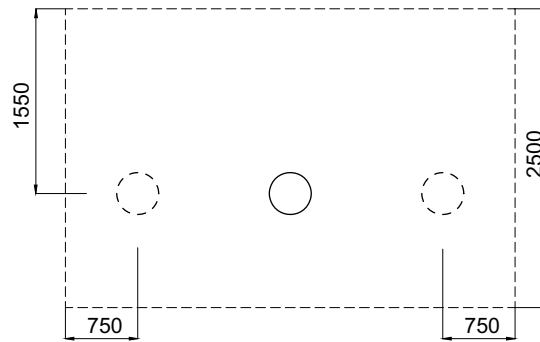
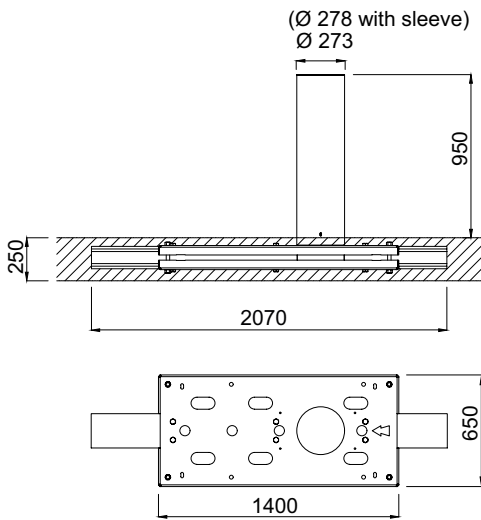

* Different product dimensions are optionally available.

Technical Features

Crash / Impact Rating

Designed and produced to withstand impacts mentioned below:

Standard	Vehicle Type	Weight	Speed
ASTM F2656	M, C7 (K-4)	6800, 7200 kg	48 km/h (30 mph)
PAS 68	N2, N3	7500 kg	48 km/h (30 mph)
IWA 14-1	N2A, N2B, N3C	7200 kg	48 km/h (30 mph)

(Please contact for applicable product dimensions.)

Bollard Structure

950 mm high bollard pipe is made of $\varnothing 273$ mm ($\varnothing 278$ mm with sleeve), 10 mm thick hot dip galvanised solid steel pipe with a reinforced design.

10 mm solid steel bar infilled inner structure for impact absorption distributed evenly to the whole body and increasing resistance.

Impact surface is painted in RAL9006 (optionally in other RAL colors).

Designed so that no vehicle crashing effect can displace it after embedded into the ground.

Furnished with red (opt. white or yellow) reflecting strips.

Bollard contains high resistant anchorage structure through 2 anchor plates with concrete immersion slits at the top and bottom, strengthened with "HEB" beams in the impact direction and adjustment bolts for leveling at 4 areas.

Underground elements are fixed together by wedge type, 10.9 grade bolted and welded connection for utmost resistance reinforcement.

Optional Features and Accessories

Removable structure (designed and produced to withstand impacts at ASTM F2656 M30, C730 (K-4), PAS 68 [N3]/48 and IWA 14-1 [N3C]/48 levels), demountable aluminium (electrostatic powder coated in body color or 304/316 grade stainless steel) bollard top lid with 360° visible red flashing LED indicators, stainless steel sleeve (304/316 grade), different colors, different product dimensions.

Installation

Easy levelling with 4 bolts and installation to 250 mm shallow depth with steel rebar reinforcement and C35 grade concrete through ground mounting plate containing concrete immersion slits. Ground levelling and preparation works shall be carried on before pouring the concrete.

Allowable bearing value of the ground shall be minimum 1/2 kg/cm², if not, works shall be carried on to fulfil. Installation shall be done according to the manufacturer's instructions.