

RBD/4 BOLLARD

(Reinforced - Fixed Model)

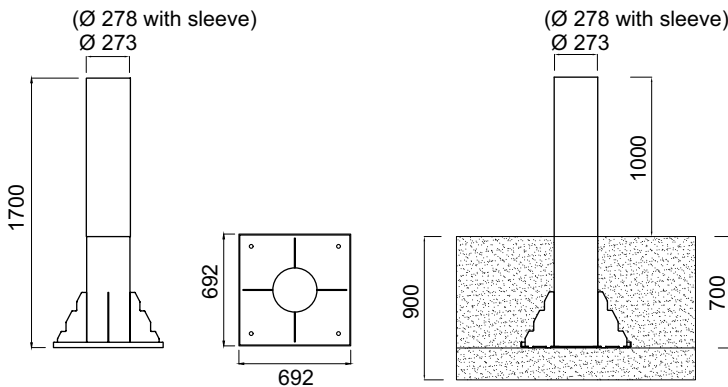

Dimensions (mm)



* Different product dimensions are optionally available.

Technical Features

Crash / Impact Rating

Designed and produced to withstand impacts mentioned below:

Standard	Vehicle Type	Weight	Speed
ASTM F2656	M, C7 (K-4)	6800, 7200 kg	48 km/h (30 mph)
PAS 68	N2, N3	7500 kg	48 km/h (30 mph)
IWA 14-1	N2A, N2B, N3C	7200 kg	48 km/h (30 mph)

(Please contact for applicable product dimensions.)

Bollard Structure

Ø273 mm (Ø278 mm with sleeve), 10 mm thick hot dip galvanised solid steel pipe, electrostatic powder coated in RAL9006 (optionally in other RAL colors) impact surface and 10 mm thick impact absorbing panel reinforced interior.

Furnished with red (opt. white or yellow) reflecting strips.

Includes 4 adjustment bolts for easy leveling, with an anchor plate of 692x692 mm welded to the impact pipe and 4 vertical anchor supports welded around the impact pipe.

Designed so that no vehicle crashing effect can displace it after embedded into the ground.

Optional Features and Accessories

Removable structure (designed and produced to withstand impacts at ASTM F2656 M30 (K-4), PAS 68 [N2/N3]/48 and IWA 14-1 [N2A/N2B/N3C]/48 levels), demountable aluminium (electrostatic powder coated in body color or 304/316 grade stainless steel) bollard top lid with 360° visible red flashing LED indicators, stainless steel sleeve (304/316 grade), different colors, different product dimensions.

Installation

Easy levelling with 4 bolts and installation with C30 grade concrete and steel rebar reinforcement. Ground levelling and preparation works shall be carried on before pouring the concrete. Allowable bearing value of the ground shall be minimum 1/2 kg/cm², if not, works shall be carried on to fulfil. Installation shall be done according to the manufacturer's instructions.