

FROG PLUS

Concealed operator
for large swing gates.





FROG PLUS is the “concealed” solution, ideal for powering uncommonly large swing gates. The system, in fact, is suited for single gate leaves measuring up to 7 m in length.



FROG PLUS

MAIN FEATURES

- Safety is ensured even when the gate is idle: each command is cancelled in case an obstruction is detected by the safety devices.
- High protection rating against weathering agents (IP67).
- Built-in opening and closing limit-switches for quick and easy adjustment of the leafs stop point.
- Display for programming and viewing features.
- Encoder-based gate travel control and obstruction detection.
- Memorizes differently coded radio commands (up to 250 users).



IT WITHSTANDS ANYTHING!

The rust-proof stainless-steel foundation box and cathaphoresis treatment, give the product a high-degree of durability. It IP67 protection rating means it is always perfectly functional, thanks to its impermeability, even in the worst of conditions.

INTERCHANGEABLE SUPPORTING PIVOT

The foundation box is fitted with a special interchangeable supporting pivot which is bolted onto the box. This makes for easy maintenance and replacement, in case of need, thus ensuring greater durability to the entire system.

THE NEW LIMIT-SWITCH SYSTEM

The gearmotor is fitted with a series of adjustable mechanical closing and opening limit-switches. There is also an additional accessory available: an electromechanical limit-switch to manage the gate leaves' stopping points. This is to avoid unwanted thrusts when the gate has reached the end of its travel.

FROG PLUS TECHNOLOGY



ENCODER

Gearmotor or operator with ENCODER.



CAME CONNECT

Developed with CONNECT technology for remote digital control via gateway or locally via CAME KEY.

READ UP AT CAME.COM ABOUT THE FULL RANGE OF CAME OPERATORS AND ACCESSORIES



TRANSMITTERS



PHOTOCELLS



SELECTORS

CAME is a leading home-automation, industrial and special plant-technology projects manufacturing company. We provide full range of solutions: gate and garage door operators, shutter and awning winding-motors, home-automation control, burglar-proof systems, and video entry systems. Technology and reliability to serve your business with solutions designed for automating industrial doors, automatic doors, street barriers, turnstiles, access control and parking facility systems.



THE COMPLETE RANGE

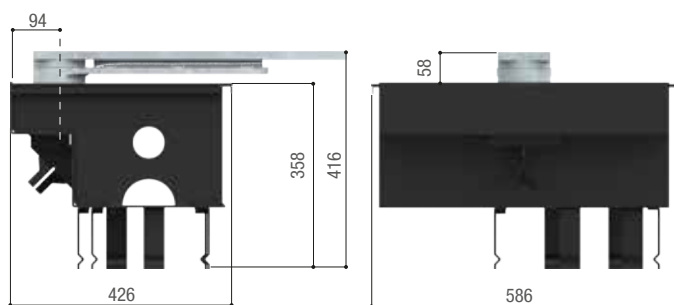

OPERATIONAL LIMITS

Max. length of leaf (m)	7	6	5,5	5	4,5	4	3,5	2,5	1,5
MODEL	FROG-PM4								
Max. weight of leaf (kg)	-	-	700	-	900	-	1100	1400	1800
MODEL	FROG-PM6								
Max. weight of leaf (kg)	550	650	-	800	-	1000	-	-	-
Max. leaf opening	110°								

TECHNICAL CHARACTERISTICS

MODEL	FROG-PM4	FROG-PM6
Protection rating (IP)	67	67
Power supply (V AC- 50/60 Hz)	230	230
Power supply to motor (V AC- 50/60 Hz)	230	230
Absorption (A)	2,1	2,1
Power (W)	500	500
Maneuvering time at 90° (s)	30	45
Cycles/Hour	10	6
Torque (N/m)	800	800
Operating temperature (°C)	-20 ÷ +55	-20 ÷ +55

● 230 V AC

© CAME SPA - KADENAOE25 - 2025 - EN

Came reserves the right to make any changes to this document at any time. Even partial reproduction is prohibited.

CAME 
MORE THAN TECHNOLOGY

CAME S.P.A.

Via Martiri della Libertà, 15
 31030 Dosson di Casier
 Treviso - ITALY

CAME.COM

We are a leading multinational company offering integrated and connected solutions for the automation of residential, public and urban environments, creating intelligent spaces designed to enhance people's wellbeing.

- GATES AUTOMATION
- AUTOMATIC BARRIERS
- GARAGE DOORS AND INDUSTRIAL CLOSURES AUTOMATION
- VIDEO ENTRY SYSTEMS
- HOME CLIMATE CONTROL
- SHUTTERS, BLINDS AND AWNINGS AUTOMATION
- ACCESS CONTROL SOLUTIONS
- TURNSTILES AND SPEEDGATES
- BOLLARDS AND ROADBLOCKERS
- PARKING SYSTEMS

